

CHARMY 90



dunia®
COOL TECH



HORECA
CHARMY 90

é uma apurada solução para exposições genuínas. Planos expositivos e iluminação de proximidade que despertam o potencial alimentar. A técnica, versatilidade e delicadeza sobressaem numa silhueta vincada pela horizontalidade. Um formato que se desdobra em versões refrigeradas, aquecidas e neutras.

is an accurate solution for genuine display. Display plans and proximity lighting that awaken food potential. Technicity, versatility and delicacy stand out in a horizontal silhouette. A format that unfolds in chilled, heated and neutral versions.

est une solution précise pour les expositions authentiques. Plans d'exposition et éclairage de proximité qui éveillent le potentiel alimentaire. La technicité, la polyvalence et la finesse se distinguent par une silhouette marquée par l'horizontalité. Un format qui se déplie en versions froides, chauffées et neutres.



**FUNCIONALIDADE
ESTÉTICA**

FUNCTIONALITY
AESTHETICS

FONCTIONNALITÉ
ESTHÉTIQUE



QUALIDADE
QUALITY / QUALITÉ

Exposição refrigerada

REFRIGERATED EXPOSITION / EXPOSITION RÉFRIGÉRÉE

+2 / +5 °C

Disponível nas versões ventilada (V), saladas (S), tampo refrigerado (TR)

Available in ventilated versions, salads, refrigerated deck

Disponible en versions ventilée, salades, plateau réfrigéré

Exposição refrigerada delicada

DELICATE REFRIGERATED EXPOSITION / EXPOSITION RÉFRIGÉRÉE DÉLICATE

+13 / +15 °C

Disponível na versão chocolates (C)

Available in chocolates version

Disponible en version chocolats

Exposição refrigerada negativa

NEGATIVE REFRIGERATED EXPOSITION / EXPOSITION RÉFRIGÉRÉE NEGATIVE

-20 / -18 °C

Disponível na versão gelados (G)

Available in ice cream version

Disponible en version crème glacée

Exposição aquecida

HEATED EXPOSITION / EXPOSITION CHAUFFÉE

+60 / +65 °C

Disponível nas versões tampo aquecido (TA), aquecida ventilada (AV) e banho-maria (BM)

Available in hot plate versions, ventilated dry heat and bain-marie

Disponible en versions plaque chaude, chauffé ventilée et bain-marie

Exposição ambiente

AMBIENT EXPOSITION / EXPOSITION AMBIANTE

- °C

Disponível nas versões neutra (N), pão (P), caixa 1 nível (CX1N), caixa 2 níveis (CX2N), caixa pessoas com mobilidade reduzida (CXPMR) e torre de vidro (TV)

Available in neutral, bread, 1-level support counter, 2-level support counter, support counter for people with reduced mobility and glass tower

Disponible en versions neutre, pain, caisse à 1 niveau, caisse à 2 niveaux, caisse pour personnes à mobilité réduite et tour à viennoiserie

MÓDULOS / MODULES / MODULES

REFRIGERADAS Refrigerated . Réfrigérée		LINEAR linear . linéaire ¹							ANGULAR Angular . Angulaire		
		700	850	1025	1250	1350	1650	2050	2450	AER	AIR
VENTILADA Ventilated Ventilée	V	-	●	-	●	-	●	●	●	90°	90°
SALADAS Salads Salades	S	●	-	●	-	●	-	-	-	-	-
TAMPO REFRIGERADO Refrigerated deck Plateau réfrigéré	TR	-	●	-	●	-	●	-	-	-	-
CHOCOLATES Chocolates Chocolats	C	-	●	-	●	-	●	-	-	-	-
GELADOS Ice cream Crème-glacée	G	-	●	-	●	-	●	-	-	-	-

T. Amb. = 25 °C; H.R. = 60%

AQUECIDAS Heated . Chauffé		LINEAR linear . linéaire ¹					
		700	850	1025	1250	1350	1650
TAMPO AQUECIDO Heated deck Plaque chaude	TA	-	●	-	●	-	●
AQUECIDA VENTILADA Ventilated dry heated Chauffé ventilée	AV	●	-	●	-	●	-
BANHO-MARIA Bain-marie Bain-marie	BM	●	-	●	-	●	-

NEUTRAS Neutral . Neutre		LINEAR linear . linéaire ¹						ANGULAR Angular . Angulaire		
		600	850	1050	1250	1650	2050	2450	AER	AIR
NEUTRA Neutral Neutre	N	-	●	-	●	●	●	●	45° 90°	45° 90°
PÃO Bread Pain	P	-	●	-	●	●	-	-	-	-
CAIXA 1 NÍVEL 1 level sup. counter Caisse 1 niveau	CX1N	●	-	●	-	-	-	-	45° 90°	45° 90°
CAIXA 2 NÍVEIS 2 level sup. counter Caisse 2 niveaux	CX2N	●	-	●	-	-	-	-	45° 90°	-
CAIXA PMR² PMR sup. counter Caisse PMR	CXPMR	-	●	●	-	-	-	-	-	-
TORRE DE VIDRO Glass tower Tour à viennoiserie	TV	●	●	●	-	-	-	-	-	-

¹ Comprimento sem laterais | Length without side panels | Longueur sans joues ² PMR – Pessoas com mobilidade reduzida / People with reduced mobility / Personnes à mobilité réduite

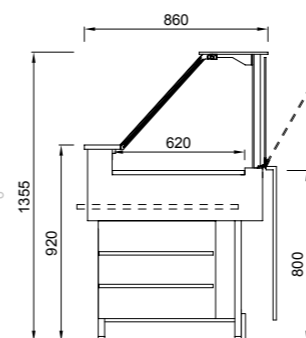
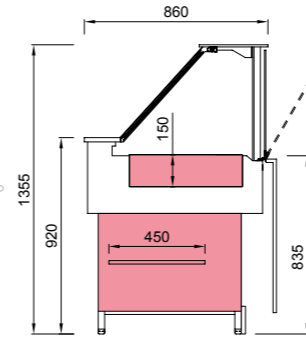
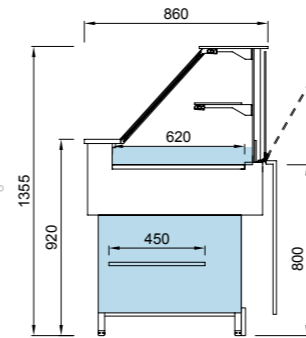

VIDRO EXPOSITIVO EXPOSITIVE GLASS / VITRAGE EXPOSITIF

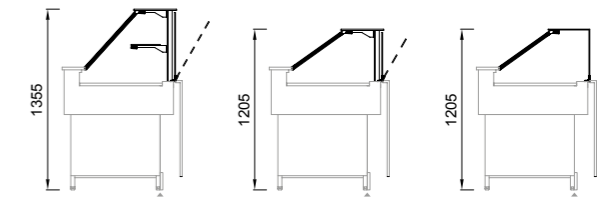

VPA

VPB

VPB UV

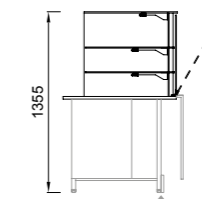

VPA TV

ÂNGULOS ANGLES / ANGLES

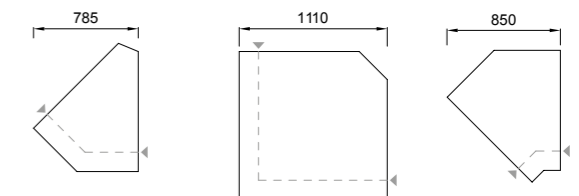

AER45

AER90

AIR45

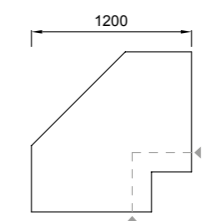

AIR90



www.dunia.pt

AVISO LEGAL / DISCLAIMER / AVERTISSEMENT

AGRADECEMOS A SUA PREFERÊNCIA.

A DUNIA reserva-se no direito de proceder a qualquer actualização sem prévia notificação. Os dados fornecidos são indicativos. A técnica de impressão pode implicar alteração nas cores reproduzidas. A informação apresentada está sujeita a alterações após publicação, certifique-se da validade da brochura.

THANK YOU FOR YOUR PREFERENCE.

DUNIA reserves the right to carry out any updating without prior notification. The data provided is indicative. The printing technique may imply a change in the colors reproduced. The information presented is subject to change after publication, please check the validity of the brochure.

MERCI POUR VOTRE PRÉFÉRENCE.

DUNIA se réserve le droit d'effectuer toute mise à jour sans notification préalable. Les données fournies sont indicatives. La technique d'impression peut impliquer une modification des couleurs reproduites. Les informations présentées sont susceptibles d'être modifiées après publication. Veuillez vérifier la validité de la brochure.

MORADA / ADDRESS / ADRESSE

Rua 1º de Maio · Parque industrial de Celeirós
Pavilhão 37 · 4705-470 Celeirós · Braga
Portugal

CONTACTOS / CONTACTS / CONTACTS

T +351 253 603 040
geral@unia.pt
www.dunia.pt



CAT_00.1124